

Customer reference case

Off-road vehicles

Boom arms

SKF filament wound bushings



Filament wound bushings increase MTBF for Herder

The boom arm on any piece of agricultural equipment is subject to heavy loads, vibrations and occasional shock loads. These booms, which use hydraulic cylinders to actuate, use bronze bushings to connect the boom segments, and steel-on-steel spherical plain bearings to “anchor” the cylinders. Both the spherical plain bearings and the bronze bushings require regular relubrication due to the water and abrasive contaminants inherent in the operating environment.

Herder, a major manufacturer of attachments for agricultural tractors was looking for an alternative solution to spherical plain bearings and bronze bushings for their booms. The manufacturer wanted a solution to reduce failures caused by improper maintenance that would also exceed existing and future environmental standards. In addition they wanted to increase mean time between failures (MTBF) of the bearings holding the hydraulic cylinders in place, without increasing costs.

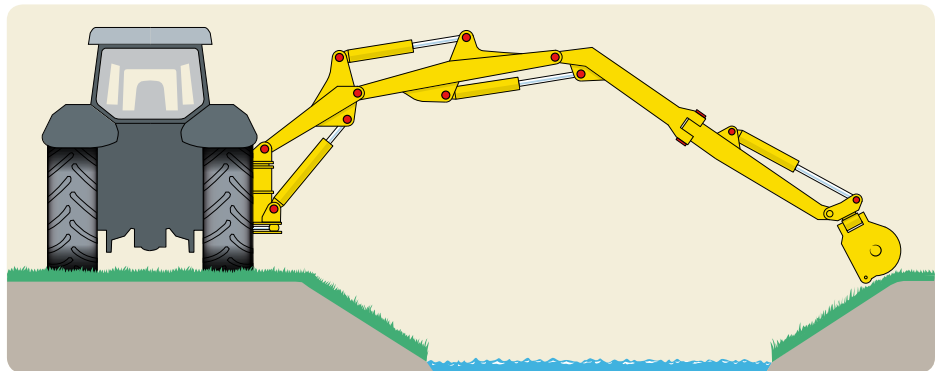

Sketch of boom with different bearing locations indicated

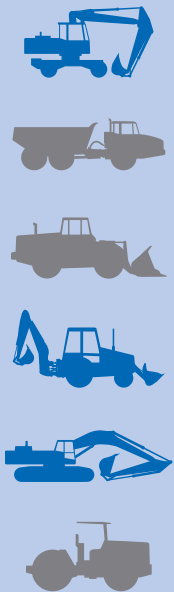

About the solution

After a thorough examination of the application, SKF application engineers recommended SKF filament wound bushings. Their research showed that filament wound bushings would accommodate the operating conditions for all but 3 locations. In all other cases, however, SKF engineers felt that SKF filament wound bushings would meet the customer's first objective to provide a maintenance-free solution and that the bushings would also increase MTBF of the cylinder ends.

After extensive field tests, it was determined that the filament wound bushings were so robust that they would last twice as long as the previous solution. In harsher environments, such as in construction machinery, SKF wiper seals are available to provide even longer service life.

Filament wound bushings provided the OEM with a lubricant-free, cost-effective solution that increased mean time between failures. They also realized another benefit: they were able to standardize the solution in all but three locations, which provided additional cost savings.

Customer benefits

- ✓ Eliminates lubricant
- ✓ Eliminates grease fittings
- ✓ Increases MTBF
- ✓ Environmentally friendly
- ✓ Reduces warranty claims
- ✓ Non-corrosive



Filament wound bushings with matching seals

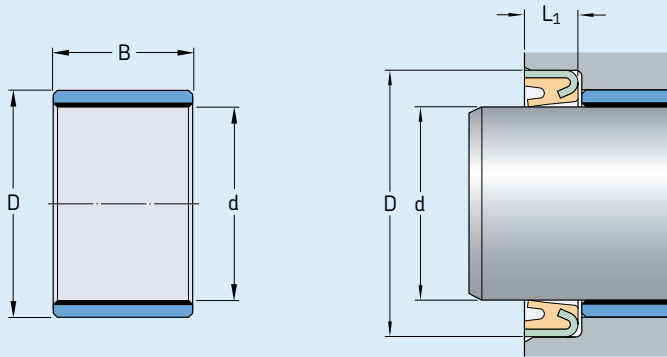

Bushing			Designation	Seal			Designation
d	D	B		d	D	L ₁	
mm			-	mm			-
40	48	30	PWM 404830	40	50	4,5	CR PAK 40×50×4.5 -L
40	48	40	PWM 404840	40	50	4,5	CR PAK 40×50×4.5 -L
40	48	60	PWM 404860	40	50	4,5	CR PAK 40×50×4.5 -L
50	58	40	PWM 505840	50	60	7	CR PAK 50×60×7 -L
50	58	50	PWM 505850	50	60	7	CR PAK 50×60×7 -L
50	58	60	PWM 505860	50	60	7	CR PAK 50×60×7 -L
60	70	40	PWM 607040	60	70	7	CR PAK 60×70×7 -L
60	70	60	PWM 607060	60	70	7	CR PAK 60×70×7 -L
60	70	80	PWM 607080	60	70	7	CR PAK 60×70×7 -L

More information about PWM bushings can be found in publication 6242. Information about PAK wiper seals can be found in publication 5397.

SKF is a registered trademark of the SKF Group.

© SKF Group 2006
The contents of this publication are the copyright of the publisher and may not be reproduced (even extracts) unless permission is granted. Every care has been taken to ensure the accuracy of the information contained in this publication but no liability can be accepted for any loss or damage whether direct, indirect or consequential arising out of the use of the information contained herein.

Publication 6274 EN

Printed in Sweden.